

FIRE AND SMOKE DAMPER MAINTENANCE

The objective of this technical bulletin is to inform BESA members of specific considerations when testing and maintaining fire and smoke dampers. It should be used alongside BESA publications: [DW/145](#): Installation of Fire and Smoke Dampers; [DW/144](#): Sheet Metal Ductwork; [TR/19](#)[®]: Internal Cleanliness of Ventilation systems and [TR19](#)[®] [Grease](#): Fire Risk Management of Grease Accumulation within Kitchen Extraction Systems. Reference should also be made to [BS9999](#): Fire safety in the design, management and use of buildings, [HTM 03-01](#): Heating and ventilation of health sector buildings and [HTM 05-01](#): Managing Healthcare fire safety. VH001 - Fire and Smoke Damper Maintenance, will be incorporated into the BESA publication [DW/145](#) - Installation and Maintenance of Fire and Smoke Dampers, currently under review.

STANDARDS

[BS 9999](#) provides a best practice framework for fire safety and includes standards for the definition, maintenance and testing of fire dampers. It states that all fire dampers should meet the criteria of fire resistance for a stated period of time and that:

“All fire dampers should be tested by a competent person at regular intervals not exceeding one year, and to be repaired or replaced immediately if found to be faulty.

Spring-operated fire dampers should be tested annually and fire dampers situated in dust-laden and similar atmospheres should be tested much more frequently, at periods suited to the degree of pollution.”

In addition; guidelines have been introduced by the department of health that encourage regular testing of fire dampers. In Part B of Health Technical Memorandum [HTM 03-01](#), fire dampers are required to be tested and maintained annually. Inspection and functional testing of smoke and fire dampers should be specified by the manufacturer.

Spring operated fusible link dampers

Spring operated fusible link fire dampers are commonly designed to activate when the temperature exceeds the limit (typically 72° C). The fusible link releases the spring loaded fire damper to contain the fire within the ductwork space. This ensures that the fire does not spread through the ductwork ventilation system.

BS 9999 defines a fusible link as a “device that releases a component such as a fire damper or fire shutter at a set temperature”.

INSTALLATION

To enable the Fire Dampers to be tested and reset access panels need to be installed. Access panels shall be quick release insulated sealed panels, all manufactured and installed to BESA specification [DW/144](#). Required location of access panel, along with party responsible for provision of the panel is prescribed in Table 3 of BESA publication [TR/19](#)[®].

Kitchen Extract Ventilation

Fire dampers should not be fitted (BS 9999:2017 Clause 32.5.2.2 and 32.5.4). Where fire dampers are still found in older installations, these systems should be tested annually, as a minimum, as required by [BS 9999](#), or removed from the system entirely. Removal is recommended and will require a review of the fire risk assessment.

Fire Stopping

The penetration seal between the damper and structural element often referred to as “Fire Stopping” materials and include, but are not limited to, vertical or horizontal builders work structures, dry-lining partitions and vertical fire blankets. The penetration seal is used to restore and maintain the fire classification of the fire separating element/barrier at the position where the damper/ ductwork pass through the barrier. The penetration seal must be installed in accordance with test methods for use when penetrated by a damper.

TESTING

Details are included in The Association for Specialist Fire protection (ASFP) [Grey Book](#) entitled Fire stopping and Penetration Seals for the Construction Industry.

Testing as described here is defined as the demonstration of the operation of the damper to suit its intended purpose.

It should be carried out according to manufacturer's recommendations however, additional procedures may be required by the client.

Prior to testing a full risk assessment should be carried out. Where dampers are fitted, specific considerations should be given to accessibility in small sized ducts.

All contractors need to have sufficient training to carry out maintenance work. Testing should include, but not limited to the following steps:

- an inventory of all dampers to be tested
- all manually resettable dampers will be released to ensure the integrity of the spring loaded shutter. On motorised fire dampers the control mode should be operated to ensure that the blades are moving from the open to the closed position and vice versa
- the Fusible link should be inspected for any deformity or damage
- the fire/smoke damper will be cleaned
- the fire/smoke damper shall then be opened and re-set
- A review of the previous inspection report to check if any modifications have been made, outstanding remedial actions have been completed

- asset register to include damper location and ID number
- Where the damper is not fully or only partially accessible due to inadequate access either in ductwork or the building fabric it must be reported to the client and remedial action recommended.
- inspection results including details of failed damper operation
- explanation of failed operation and recommended corrective or remedial action
- if a fusible link has failed it should be reported to client who must take remedial action
- any severe corrosion or damage found shall be reported to the client
- if drawings are provided, update and annotate details
- digital photographic evidence of damper condition prior to and after testing procedures unless otherwise specified by client
- visual assessment of fire stopping integrity and/or damage observed to immediate area of fire damper
- damper fixing should be checked as far as is practicable to be in accordance with manufacturer specification, for example - drop rods fixed to securing lugs on damper frames / correct riveted fixing of duct to damper frames and damper fixing to the wall
- fire and smoke damper closure to be checked to correctly indicate on the relevant fire panel where applicable
- where lubrication is required the damper manufacturer's specific instructions should be followed or, in the absence of these, a PTFE lubricant should be used to minimise adhesion and dust

REPORTS

Reports should include, but are not limited to::

- test results with client information including position within the building/system, date, and name of operative shall be recorded and any comments noted if further action is required

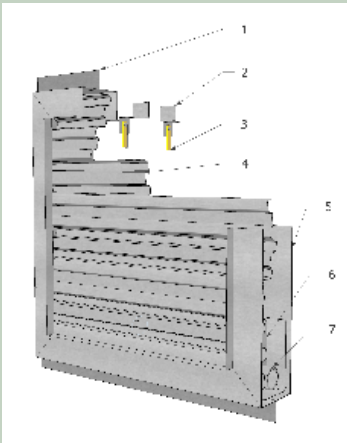

1. **Installation Frame** - Designed to integrate the damper into the partition. Available as a HEVAC or plate frame.
2. **Link Bracket** - Retains the fusible link.
3. **Fusible Link** - Retains the Blade pack in a recessed position under normal operating conditions. Splits into two parts to release blades upon reaching rated temperature (usually 72°C), this ensures the fire does not spread through the ductwork ventilation system.
4. **Blade Pack** - Interlocking steel blades which concertina into the header during normal operating conditions. When the fusible link splits the blade pack is pulled closed by the blade springs.
5. **Case** - The main body of the damper, comprising elements including the header and spigots.
6. **Lock Guide** - Two fitted to each damper, act to retain the blade springs and also lock the blade pack in position when closed.
7. **Blade/Flat Coil Spring** - Fully extended during normal operation. When the fusible link splits, the blade springs pull the blade pack down and into the lock guides.

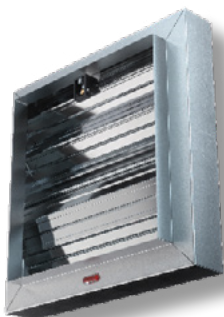

Curtain bladed fire damper



Motorised fire damper

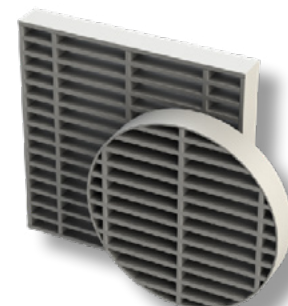

Intumescent fire damper

SFG20 - The definitive standard for planned maintenance, sets out specific actions required as follows:

CRITICALITY	ACTIONS	FREQUENCY	SKILL SET
High	All Fire and Smoke Dampers Visually inspect the fire damper's internal components for signs of corrosion, dirt or dust. Clean and lubricate the damper and perform a drop test. Collect digital photographic evidence of damper condition prior to and after testing procedures	12 months	Competent Person (Fire)
High	Electro Mechanical Fire and Smoke Dampers Inspect latching mechanism, operating cable and remote controller (incl. indicator lamp). Ensure cleanliness of, damper guide channels, springs and around the units on completion. Check and ensure correct operation of shutter mechanism. Ensure free fall of damper(s). Check and ensure security of all access doors and gaskets. State possible sources of air leakage. Report any defects and record all actions undertaken. Collect digital photographic evidence of damper condition prior to and after testing procedures	12 Months	Competent Person (Fire)
High	Air Transfer Fire and Smoke Dampers Inspect latching mechanism, operating cable and remote controller (incl. indicator lamp). Ensure cleanliness of, damper guide channels, springs and around the units on completion. Check and ensure correct operation of shutter mechanism. Ensure free fall of damper(s). Check and ensure security of all access doors and gaskets. Check for air leaks. Report any defects and record all actions undertaken. Collect digital photographic evidence of damper condition prior to and after testing procedures	12 Months	Competent Person (Fire)
High	Intumescent block fire dampers This type of damper can become blocked and impeded. They should therefore be part of the maintenance programme.	12 months	Competent Person (Fire)
High	Thermal fuse and Intumescent Air Valves Remove and replace units in accordance with manufacturers guidance as required to allow cleaning and inspection.	12 months	Competent Person (Fire)

MAINTENANCE

Thermal fuse and Intumescent Air Valves released at 72°C

1. Recommended cleaning intervals of every 12 months
2. Removal and replacement of units, in accordance with manufacturers guidance, to allow for cleaning and inspection

Note: Do not use hot water or high temperatures during cleaning, as this could cause unnecessary release of the damper.

COMPETENCY

Health Technical Memorandum [HTM 05-01](#): Managing healthcare fire safety Second Edition and [WHTM 05-02](#) and [SHTM 83](#) in Wales and Scotland - set out recommendations and guidance for the management of fire safety in healthcare buildings. It defines a Competent Person as an individual 'who can provide skilled installation and/or maintenance of fire-related services (both passive and active fire safety systems). Specifically, in HTM 05-01 (England) Clause 7.26 states that:

'Installers and maintainers of fire safety equipment will be commissioned by the trust and must be able to demonstrate a sound knowledge and specific skills in the specialist service being provided. This may include the installation and/or maintenance of related fire safety equipment/services such as fire alarms and detection systems.'

LEGISLATION

With the enactment of the [Regulatory Reform \(Fire Safety\) Order 2005](#), it is now the employer's responsibility to maintain their fire safety systems. [BS 9999](#) Annex W.1 Inspection and Maintenance (Note 2), also states that:

'Arrangements should be made for all fire dampers to be tested by a competent person on completion of the installation and at least annually, and to be repaired or replaced immediately if found to be faulty.'

Note: This document is based on knowledge available at the time of publication and is meant for general purposes, not for reliance on in relation to specific technical legal issues, in which case you should always seek independent advice. No responsibility of any kind for any injury, death, loss, damage or delay however caused, resulting from the use of this advice and recommendations contained herein is accepted by the authors or others involved in its publication (including the Building Engineering Services Association). **January 2020.**

